

Experimental Study on the Down-Speed of Conductor Pipe Influenced by Jetting Displacement in Deepwater Drilling

ZHANG Hongkun^{[a],*}; GUO Yanli^[a]; FAN Zhi^[b]; HUANG Mingzhao^[c]; WANG Lingxiao^[a]; CHEN Jiahui^[a]; SUN Baojiang^[a]

^[a] College of Petroleum Engineering, China University of Petroleum, Qingdao, China.

^[b] Changqing Oilfield Company, CNPC, Xi'an, China.

^[c] Offshore engineering company drilling division, CNPC, Tianjin, China.

*Corresponding author.

Supported by CNPC's Science and Technology Research Projects: Experiment of Jetting Conductor Real-Time Bearing Capacity Calculation (GCY-EC-14-12-8), Research on Key Equipment and Safety Testing Technology of Marine Drilling (2014B-4315).

Received 20 October 2015; accepted 25 November 2015
Published online 31 December 2015

Abstract

Based on the theory of jet drilling technology and displacement optimization, a set of experimental equipment about jet drilling is devised. The laws of conductor pipe down-speed influenced by pump displacement were studied by laboratory experiments. According to the experimental results and analysis, the following conclusions can be drawn. The down-speed of conductor pipe increases with the increasing of displacement, also the drilling speed is boosted. But the unstableness of borehole wall is augmented as well. And this will result in the increasing of waiting time for borehole formation. In the process of conductor pipe jetting, the conductor pipe down-speed and the waiting time of soil returning to a certain bearing capacity should be considered together in order to shorten the entirety drilling time. The research can provide certain references for expensive offshore operation and have important significance to improve the economic benefits of deepwater drilling.

Key words: Jet drilling; Conductor pipe; Down-speed; Displacement; Borehole stability; Waiting time

Zhang, H. K., Guo, Y. L., Fan, Z., Huang, M. Z., Wang, L. X., Chen, J. H., & Sun, B. J. (2015). Experimental study on the down-speed of conductor pipe influenced by jetting displacement in deepwater drilling. *Advances in Petroleum Exploration and Development*, 10(2), 88-92. Available from: URL: <http://www.cscanada.net/index.php/aped/article/view/7742> DOI: <http://dx.doi.org/10.3968/7742>

INTRODUCTION

Jet pipe drilling technology is a crucial technology in deepwater drilling, it has advantages as follows: Being free of cementing, saving time, boosting drilling speed, simplifying drilling procedure and reducing cost^[1-2]. Important parameters in jet drilling include bit pressure, jetting displacement, nozzle angle of bit, and so forth. The optimization of displacement has great significance towards improving jet drilling efficiency and economic benefits^[3-4]. Currently, various authors have attempted to explain the process of soil damage by fluid jet. The research on surface conductor running technology for deepwater jetting mainly focuses on the determination of conductor setting depth, subsea wellhead stability and engineering application examples^[5-8]. Event T.G et al.^[9] summarized empirical formulas to calculate part of jetting parameters. Liu Shujie et al.^[10], Wang Chengwen et al.^[11] and Yang Jin et al.^[12] studied the mechanism of surface jetting drilling in deep water, and also analyzed the influence of parameters such as bit pressure to soil damage.

In this work, the laws of various aspects in the process of jet drilling influenced by different displacements were studied through multigroup experiments. The conductor pipe down-speed and the waiting time which is required to form stable borehole were analyzed on the purpose of shortening the project period and providing reference for surface drilling in deepwater.

1. EXPERIMENT

1.1 Experimental Setup

According to the technological characteristics of jet drilling and theoretical analysis, an experimental equipment is built to mimic the jet drilling progress in deepwater. The experimental flow chart is shown in Figure 1.

The pump can provide displacement of 20 L/min to 63 L/min and three-phase asynchronous motor is its

power. Manufacturers are Jiangsu Oil Technology Limited Liability Company, as shown in Figure 2. Electromagnetic flowmeter, used to read the displacement, is shown in Figure 3. Soil box, 70 cm long, 70 cm wide, 130 cm high, filled with sand, is used to mimic the conditions of offshore drilling. Conductor pipe, 100 cm length, with holes at the top, is used to return jetting fluid and soil, as shown in Figure 4. Jetting bit connects with conductor pipe, as shown in Figure 5.

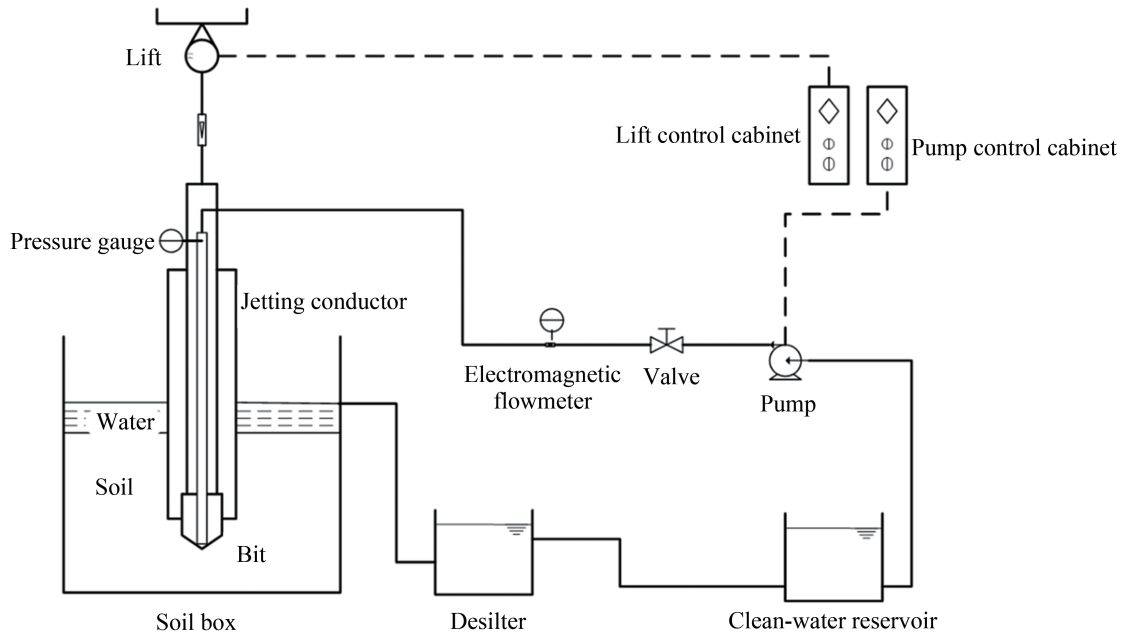

Figure 1
Experimental Flow Chart



Figure 2
Pump and Three-Phase Asynchronous Motor



Figure 3
Electromagnetic Flowmeter



Figure 4
Soil Box and Conductor Pipe



Figure 5
Jetting Bit

1.2 Experimental Method

The experimental device should be connected according to the flow chart. Open the pump through the pump control cabinet, and combined with valve and the electromagnetic flowmeter to adjust displacement to a certain value. Jetting conductor running is controlled by elevator control cabinet. Timing starts when conductor pipe contacts with soil and ends when conductor pipe is almost in soil. And record down the depth of the conductor pipe in soil. The average down-speed of conductor pipe can be computed through the depth and time under the condition of different displacements. Wait for half an hour and then the jetting conductor is lifted up through the elevator control cabinet. Observe the borehole characteristics and take photograph on purpose of comparing with other experimental groups. Change the displacement, repeat more groups of experiment.

1.3 Experimental Material

The soil used for experiments is sand soil and the water is running water. The basic parameters of sand soil is shown in Table 1.

Table 1
Basic Parameters of Sand Soil

Soil type	Density (Kg/m ³)	Cohesion (KPa)	Internal friction angle	Permeability coefficient (cm/s)
Sand soil	2.07	11.5	22.5°	1,205.7×10 ⁻⁷

2. RESULTS AND DISCUSSION

Through multiple sets of experimental data the conductor pipe average down-speed can be calculate. As shown in Tables 2 and 3.

Table 2
Experimental Data of Bit With 30° Nozzle Angle

Displacement (L/min)	Depth (cm)	Time (min)	Speed (cm/min)
20	59	5.78	10.21
30	59.5	3.88	15.34
40	63	2.02	31.19
45	68.5	1.97	34.77
50	64.5	1.62	39.81

Table 3
Experimental Data of Bit With 60° Nozzle Angle

Displacement (L/min)	Depth (cm)	Time (min)	Speed (cm/min)
20	55.5	10.95	5.07
30	59.5	8.88	6.70
40	62.5	4.88	12.81
45	65.5	2.97	22.05
50	69	2.38	28.99

According to these experimental data the curve of conductor pipe down-speed varying with displacement can be got. As shown in Figure 6.

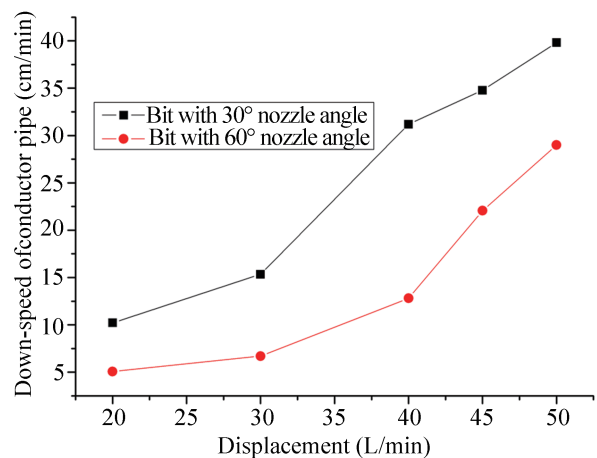

Figure 6
The Curve of Conductor Pipe Down-Speed Varying With Displacement



(a) Borehole With the Displacements of 20 L/min



(b) Borehole With the Displacements of 30 L/min



(c) Borehole With the Displacements of 50 L/min



(d) Borehole With the Displacements of 60 L/min

Figure 7
The Comparison Diagram of Borehole Formed With Different Displacements

It can be seen from Figure 6 that the pipe down-speed of conductor rising with the increasing of displacement. And the down-speed of conductor pipe decline with the increasing of nozzle angle. Therefore, from the consideration of conductor pipe down-speed, the greater the displacement the better it will be.

Figure 7 is borehole photos with different displacements. The waiting time is 30 min, and the nozzle angle of bit is 30° .

It can be seen from the Figure 7 that Borehole with the displacements of 20 L/min is very straight, and the borehole wall is smooth and complete. Borehole with the displacements of 30 L/min is relatively good. There is part of collapse in borehole with the displacements of 50 L/min. Borehole with the displacements of 60 L/min is unstable. After the conductor pipe is lifted up, it will collapse immediately. Therefore, the conductor pipe down-speed will rise with the increasing of displacement. But the jetting with high displacement makes a big disturbance on soil, and the waiting time to form stable borehole will became long. If the waiting time is not long enough, recovery degree of soil bearing capacity is small and it is easy to cause borehole collapse.

CONCLUSION

(a) Based on the theory and process features of jetting drilling technology, an experimental setup was designed for simulating the jetting of conductor pipe. The effects of displacement on the conductor down-speed and borehole stability were studied by experiments. It shows that the conductor down-speed increased with the increasing of displacement, while the borehole stability decreased.

(b) The waiting time for borehole formation increased with the increasing of displacement. If there were not enough waiting time, the aftereffect of high pressure jet could cause a partial or complete collapse of borehole wall. A chosen displacement considering the effect of conductor down-speed and waiting time can help for improving the drilling speed and decreasing the construction cost.

(c) A 1/10 scale experimental model was constructed and tested to study the jetting drilling technology, and a hydraulic rotary bit was used for simulating the rotary drill string, which saved labor and materials and achieved better results.

REFERENCES

- [1] Yang, J., Liu, S. J., Zhou, J. L., Wang, P. S., Tang, H. X., Luo, J. F.,... Zhou, C. S. (2010, June). *Research of conductor setting depth using jetting in the surface of deepwater*. Paper presented at International Oil and Gas Conference and Exhibition in China, Beijing, China.
- [2] Beck, R. D., Jackson, C. W., & Hamilton, T. K. (1991, October). *Reliable deepwater structural casing installation using controlled jetting*. Paper presented at SPE Annual Technical Conference and Exhibition, Dallas, Texas.
- [3] Quiros, G. W., & Little, R. L. (2003, May). *Deepwater soil properties and their impact on the geotechnical program*. Paper presented at Offshore Technology Conference, Houston, Texas.
- [4] Akers, T. J. (2008, March). *Improving hole quality and casing-running performance in riser less top holes: Deepwater Angola*. Paper presented at IADC/SPE Drilling Conference, 4-6 March, Orlando, Florida, USA.
- [5] Yahiro, T., & Yoshida, H. (1973). Induction grouting method utilizing high speed water jet. *Proceedings of the Eighth International Conference on Soil Mechanics and Foundation Engineering*, 4, 359-362.
- [6] Tang, H. X., Luo, J. F., & Ye, J. H. (2011). Designing method of conductor setting depth for ultra-deepwater jetting drilling in the south China sea. *Journal of Oil and Gas Technology*, 33(3), 147-151.
- [7] Su, K. H., Guan, Z. C., & Su, Y. A. (2008). Determination method of conductor setting depth using jetting drilling in deepwater. *Journal of China University of Petroleum*, 32(4), 48-50.
- [8] Zhang, H., Gao, D. L., & Tang, H. X. (2010). Tubular mechanics in jetting operation of conductor under deepwater condition. *Acta Petrolei Sinica*, 31(3), 516-520.
- [9] Events, T. G., Feyereisen, S., & Rheume, G. (2002, November). *Axial capacities of jetted well conductors in Angola. Offshore Site Investigation and Geotechnics 'Diversity and Sustainability'*. Paper presented at Proceedings of an International Conference, London, UK.
- [10] Liu, S. J., Yang, J., & Zhou, J. L. (2011). Research on relationship between weight-on-bit and drilling rate during jetting drilling in sub-bottom deepwater. *Oil Drilling & Production Technology*, 33(1), 12-15.
- [11] Wang, S. W., Yang, J., & Yan, D. (2012). The mechanism research of surface conductor jet drilling. *Journal of Oil and Gas Technology*, 34(8), 157-160.
- [12] Yang, J., Yan, D., & Tian, R. R. (2013). Bit stick-out calculation for the deepwater conductor jetting technique. *Petroleum Exploration and Development*, 40(3), 367-370.