

Biomechanics Characteristics of New Type Artificial Hip Joint¹

JIANG Hai-bo²

LIU Hong-tao³

HAN Shu-yang⁴

LIU Fen⁵

Abstract: The structure, geometrical shape and material are the three main parts of the prostheses. This research focuses on the geometrical shape analysis. The geometrical shape of human natural femoral head is similar to the ellipse, but, the artificial femoral head is rotundity shape. There is difference between ellipse and rotundity femoral head. Two models are developed and analyzed in this paper under same conditions used Finite element analysis method. Based on the calculation results, it is shown that the ellipse shape femoral head have the similar characteristics to the natural joint than rotundity model. The ellipse has the more lowness stress distribution area and more small distortion magnitude than rotundity shape artificial femoral head. It should have the more kind effect replace rotundity femoral head with ellipse shape artificial formal head.

Keywords: hip joint; prosthesis design; finite element analysis; biomechanics

INTRODUCTION

The hip joint is a major structure within the human body, which weight of the upper body and decreases the impulsion loading from lower body to the upper body. Experimental studies have found that the resultant force acting through the hip joint during normal walking is around 300% body weight. The hip joint could be destroyed under complex working conditions. Total hip arthroplasty (THA) using artificial prosthesis is a widely used treatment for osteoarthritis and similar disabling conditions since 1979. The causes of such

¹ This study was funded by the General Program of Natural Science Foundation for Colleges and Universities in Jiangsu Province (09KJD460005) and the Natural Science Foundation of Xuzhou Normal University (08XLR13).

² School of Mechanic and Electrical Engineering, Xuzhou Normal University, Xuzhou 221116, China.

³ School of Mechanic and Electrical Engineering, China University of Mining and Technology, Xuzhou 221116 China,; Biotribology center national state key laboratory of tribology, Xuzhou 221116, China.

⁴ School of Mechanic and Electrical Engineering, China University of Mining and Technology, Xuzhou 221116 China,; Biotribology center national state key laboratory of tribology, Xuzhou 221116, China.

⁵ Xuzhou City Centre Hospital, Xuzhou, 221008 China.

* Received 10 May 2010; accepted 29 July 2010

disabilities often involve the multitudinous reasons. But, after the THA, there are many patients have the joint problems for the reason about prosthesis. Through the years, there have been changes in prosthesis, but, the ideal prosthesis similar to the natural joint is not been developed. The structure, geometrical shape and material are the three main parts of the prostheses (Pyburn & Goswami, 2004; Godest et al., 2002; Scott et al., 2005; LI et al., 2005; JIANG, 2007; Yoshida et al., 2006; El'Sheikh et al., 2003).

According to the statistical measure data, the geometrical shape of human natural femoral head is similar to the ellipse. But, a great number of the artificial femoral head is sphere shape or similar to the rotundity shape (Fig.1). There is difference between ellipse and sphere femoral head that could cause the mechanics and biology problems.



Fig. 1: The natural femoral head (left) and prosthesis (right)

METHODS

A Models

Two three-dimensional finite element meshes (Fig.2) were zoned from CAD models, using a commercially available pre-processing program. One model meshes generated were that of a commonly used total hip system, and the other designed based on the true femoral head statistical data. Fully nonlinear frictional sliding contact finite element analyses were conducted using the Ansys program. The two models each consisted of two parts, the acetabulum components and femoral component head and neck. The sphere model consists of an acetabulum cup with an inner diameter set at 29mm while the interface layer between the lining and the backing is set at 45mm (Fig.2). The femoral head is set at a 28mm and a 0.5mm clearance between the cup and the femoral head. The ellipse model and lining have the dimension shown in Fig.3. There are 0.5mm clearance between the cup and the femoral head either.

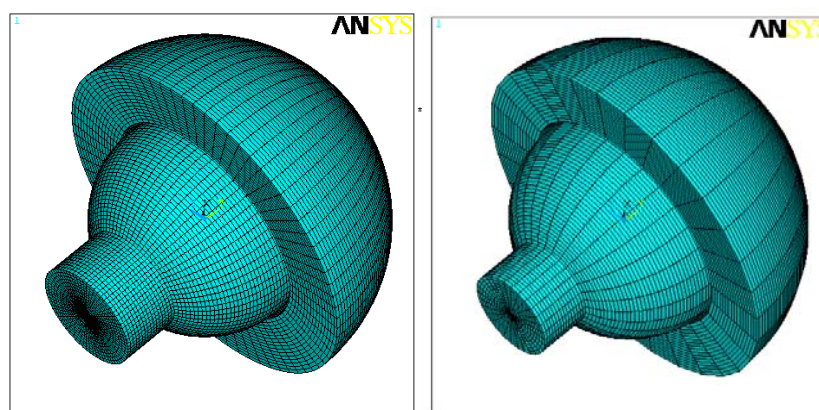

Fig. 2: Sphere model (left) and ellipse model (right)

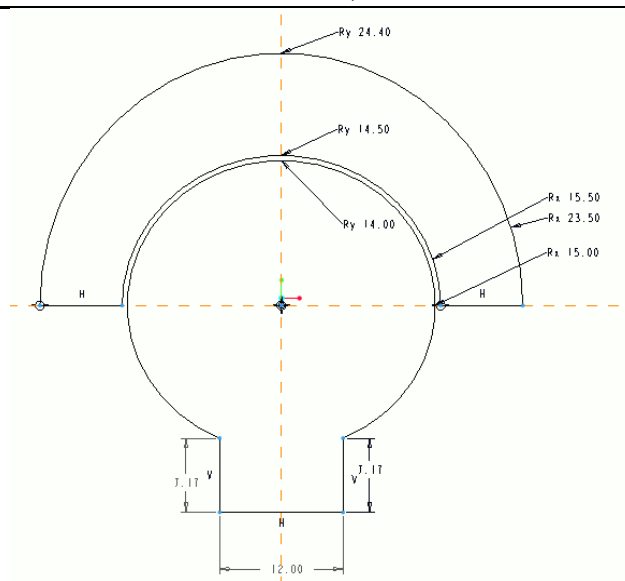

Fig. 3: The ellipse CAD model

B Material

The femoral head is assumed to be made in Ti6Al4V and the Young's Modulus of 110GPa and poisson ratio 0.3. The UHMWPE lining is more popular in the artificial acetabulum. The lining was taken to be 8mm thick having a Young's Modulus of 1.4 GPa and a Poisson's ratio 0.3.

C Boundary conditons

The boundary conditions consisted two parts, static and dynamic (Cheal et al., 1992). In the static analysis, the models simulate the human standing status. In standing status the joint bears approximately one third of the human weight, assuming human weight to be 60Kg, then the load on the hip joint was assumed to be 200N. The direction of the force points to the centre of the femur head. In the analysis, the degree of freedom (DOF) of acetabulum backing should be fixed in order to simulate the standing status. The loading time is one second.

Usually, normal walking is the most common status during day life. The magnitude and distribution of stress and displacement in this course become more important in order to understand the working status of the artificial joint. The dynamic process analysis is the key point of this work which can benefit the evaluation and redesign of artificial joint.

RESULTS AND DISCUSSION

The fig.4 and fig.5 are the deformation and stress of acetabulum. From the images, the distributions of sphere model have the bigger region than ellipse model in deformation and stress. The sphere model has the smallest magnitude on the bottom of acetabulum, shown with blue color, and the biggest value on the inner circle of the acetabulum, shown with red color. The peak deformation of sphere model is 4.695mm and ellipse is 4.749mm. The peak stress of sphere model is 1.586MPa and ellipse is 1.455MPa.

The fig.6 and fig.7 are the deformation and stress of femoral head. From the images, the distributions of sphere model have the smaller region than ellipse model in deformation and stress. The displacement and stress region of ellipse model have the same value, as shown in fig.6 and fig.7 (right). But the sphere one has the grads distribution, as shown in fig.6 and fig.7 (left). Contrast sphere and ellipse model, the sphere has more high stress concentration probability than ellipse one.

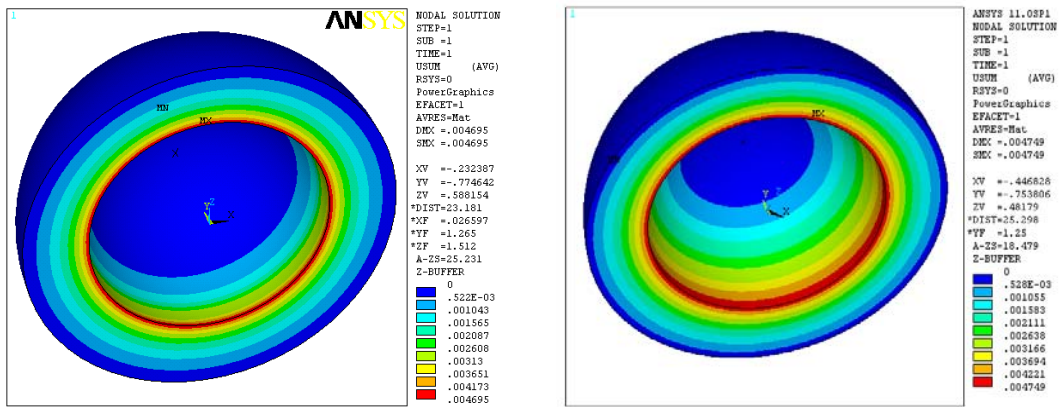

Fig. 4: The deformation of acetabulum sphere (left) ellipse (right)

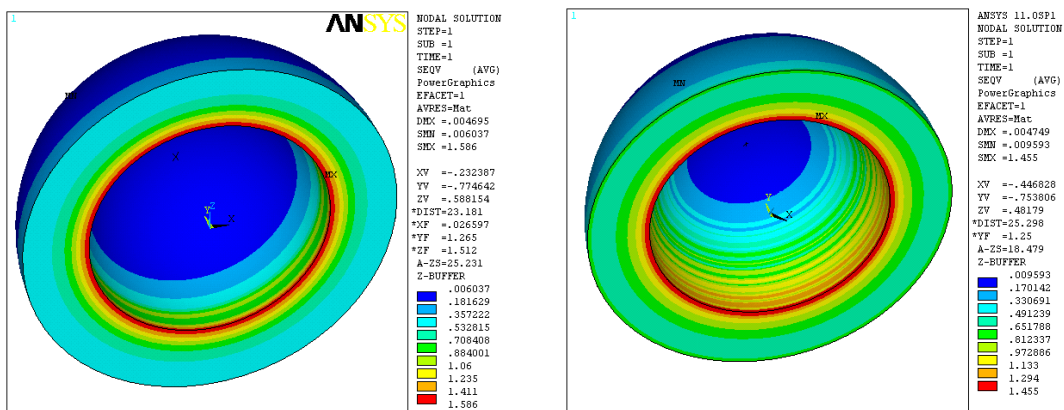

Fig. 5: The stress of acetabulum sphere (left) ellipse (right)

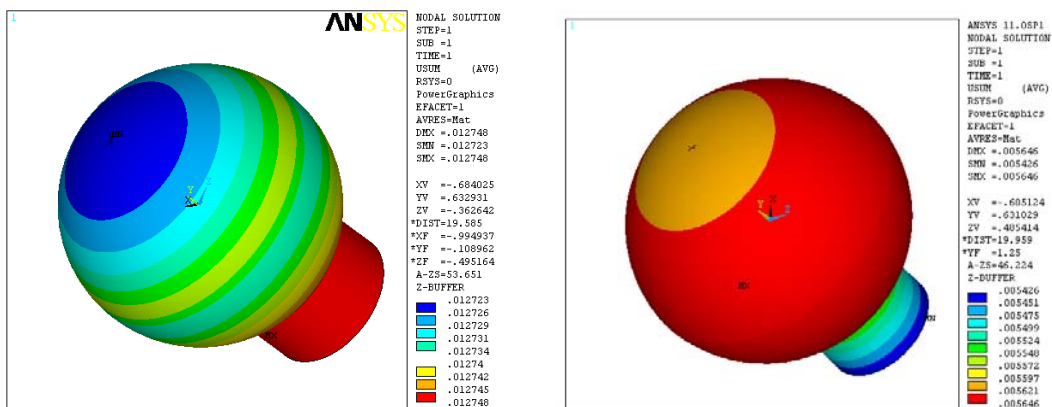

Fig. 6: The deformation of femoral head sphere (left) ellipse (right)

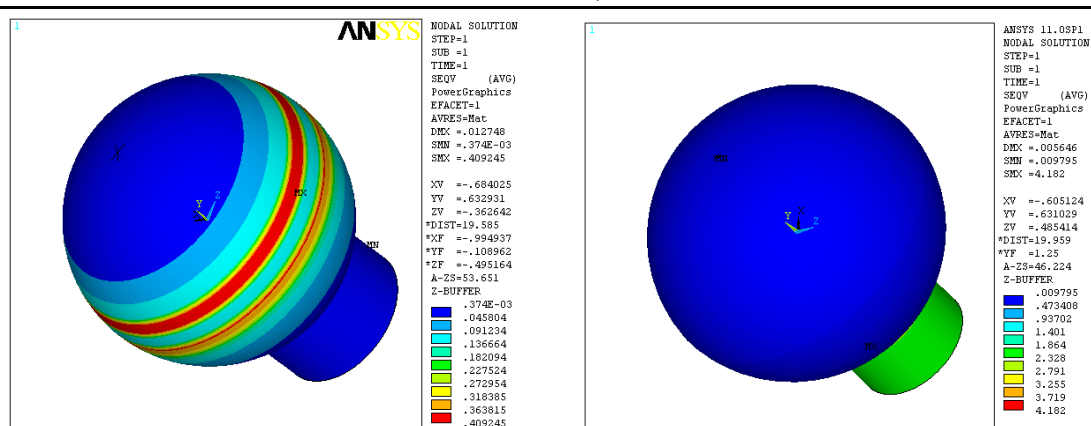

Fig. 7: The stress of femoral head sphere (left) ellipse (right)

CONCLUSION

As the results shown, the ellipse model has the higher deformation and lower stress than sphere model and lower stress concentration phenomenon that can decrease the triturate. Based on the structure of the hip joint, the ellipse model is closer to the natural hip joint than sphere model. The mechanics characteristics of the new type model are better than the sphere one. Finally, the artificial hip joint should change the sphere structure design and made it with the ellipse shape.

REFERENCES

- A.C.Godest, M.Beaugonin, E.Haug, M.Taylor, P.J.Gregson. (2002). Simulation of a knee joint replacement during a gait cycle using explicit finite element analysis [J]. *Journal of biomechanics*, 35, 267-275.
- Cheal EJ, Spector M, Hayes WC. (1992). Role of loads and prosthesis material properties on the mechanics of the proximal femur after total hip arthroplasty [J]. *Journal of orthopaedic research*, 10: 405-422.
- E.Pyburn, T.Goswami. (2004). Finite element analysis of femoral components paper III-hip joints [J]. *Material & Design*, 25, 705-713.
- H. F. El'Sheikh, B. J. MacDonald, M. S. J. Hashmi. (2003). Finite element simulation of the hip joint during stumbling: a comparison between static and dynamic loading [J]. *Journal of Materials Processing Technology*, 143-144: 249-255.
- H.Yoshida, A.Faust, J.Wilckens. et al. (2006). Three-dimensional dynamic hip contact area and pressure distribution during activities of daily living [J]. *Journal of biomechanics*, 39: 1996-2004.
- JIANG Haibo. (2007). Static and dynamic mechanics analysis on the artificial hip joints with different interface designs by finite element method [J]. *Journal of Bionic Engineering*, 4(2): 123-131.
- LI Wei, LU Hao, SUN Kang. et al. (2005). Three-dimensional finite –element analysis of composite and metal femoral prosthesis [J]. *Orthopaedic biomechanics materials and clinical study*, 2, 1-4,(in chinese).
- Scott L.Bevill, Grant R.Bevill, Janaki R.Penmetza. et al. (2005). Finite element simulation of early creep and wear in total hip arthroplasty [J]. *Journal of biomechanics*, 38, 2365-2374.