

## Bridge Designing Based on the New Combined Stretch-Shear Deformation Formula

HUANG Shuanghua<sup>[a]</sup>; HAN Wenba<sup>[a]</sup>; CAI Bingqing<sup>[a],\*</sup>; WANG Jie<sup>[a]</sup>

<sup>[a]</sup>Panzhuhua University, Panzhuhua, China.  
\*Corresponding author.

Received 9 May 2015; accepted 25 July 2015  
Published online 26 September 2015

### Abstract

This paper discovered a phenomenon in which the mass point in unit cell cannot keep balance in current elastic theory. Under different stress states, the absolute values of all equilibrium stress on the mass point are greater than the absolute values of principal stress. Thus, based on new concept of point stress balance, this paper introduces the new formula of stretch-shear combined deformation. The new formula explains the issue that, in the state of stretch-shear, constructions destroy more easily than in the state of compress-shear. Besides, based on new concepts of point stress balance, this paper also establishes a new theory of strength that is much more accurate than the third and fourth strength theory, validated in the Damage Mechanics National Key Laboratory of Tsinghua University. Comparisons of experiment data show the errors calculated from the new theory are only 1%, while errors based on the third and fourth strength theory are 14.2% and 18.2%. Therefore, the author suggests using the new stretch-shear formula to solve problems in bridge engineering in the future.

**Key words:** The balance of unit cell; Balance stress of mass point; Theory of strength; Bridge

Huang, S. H., Han, W. B., Cai, B. Q., & Wang, J. (2015). Bridge Designing Based on the New Combined Stretch-Shear Deformation Formula. *Advances in Natural Science*, 8(3), 14-19. Available from: <http://www.cscanada.net/index.php/ans/article/view/7562>  
DOI: <http://dx.doi.org/10.3968/7562>

### INTRODUCTION

With the development of the country, more and more roads and bridges are constructed. Unfortunately, there are endless numbers of bridges collapsing as well. Previously, quality was thought to be the main cause of the incidents. The incidents were also associated with defects and errors in the elastic theory itself. As new theory points out, the balance of the principal element cannot guarantee the balance of its particles, when the particles are balanced, stress should be greater than the principal stress of element balance (extreme stress). Tensile, shear and deduces the conditions of the new state of plane stress strength formula:  $\sigma' = \sqrt{\sigma^2 + 2\sigma\tau + 2\tau^2}$ .

The combined strength formula is more accurate and precise than the second and the third strength theory formulas. The Damage Mechanics National Key Laboratory of Tsinghua University has validated this theory. Especially the present elasticity theory: "Role in the torque limit on unit area (moment) should be constant zero" and should "the non-zero point force moment elasticity theory demonstrates the moment to non-zero". Shear stress distribution within the beam is deduced with classical theory is completely different, especially the point of maximum shear stress, the classic theory of shear stress on the neutral axis; under the new theory on the beam, the largest stress. In the beam, the beam of the maximum normal stress and surface area, Description on the beam, the points on the surface is tensile, shear plane stress state; description on the beam, the points on the surface is tensile, shear plane stress state; the classical theory of normal stress and shear stress is not the same point. Therefore, the present design of the beam is carried out by one-way maximum stress. In order to ensure the

safety of the beam, the design of new combination tensile, shear strength formula must be adopted.

## 1. STRAIGHTUNIAXIALLY STRETCHED ETC. OBLIQUE CROSS SECTION OF A PARTICLE CANNOT BALANCE THE CONTRADICTION

### 1.1 Such As Rods Stretching From Any Point on the Inclined Section of the Normal Stress and Shear Stress (Liu, 2000)

Such as, rods stretching shown in Figure 1 (a). As is known to all, any particle in the rod is the equal and

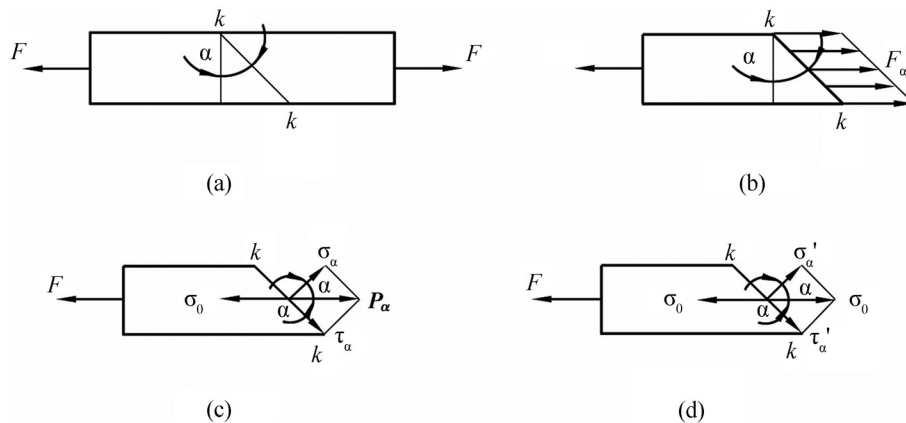

**Figure 1**  
Straight Rod Stretching, Etc.

### 1.2 The Difference Between the Unit Body Balance and Balance of Particles

An important conclusion: The balance of the elements of stress by area of force balance. The particle balance only stress balance does not need to use stress by the area to get the force to balance because, the concept of particle is a point of quality. The point not size; if consider area is also any point, on any hand, the area is equal, it can be canceled in the balance equation. Therefore, the important distinction between the particle and the cell body balance with the role of stress in the particle.

### 1.3 Inference

Figure 1 shows straight rod stretching inclined section of any interception, namely Angle  $\alpha$  can from  $0^\circ$  to the  $180^\circ$ . Any point in this way can put the rods in the point of the slope as a unit cell, therefore, can draw important corollary: any particles on the balance of the unit cell balance under the action of stress in unit cell is not in balance.

### 1.4 Keep the Balance of Particles Straight Rod Stretching on the Inclined Section, Such as the Normal Stress and Shear Stress

To ensure the slope  $k - k$  a particle of a balance, must make  $\sigma_{0\text{left}} = \sigma_{0\text{right}}$ . (d) is shown in Figure 1. It is an obvious conclusion: Simple tension as straight rod inside is affected

opposite direction of tensile stress in balance, but the current theory of elasticity cannot make particles inside the rod be in equilibrium.

A rod axial tension for  $F$ , Cross section area of  $A$ , the normal stress in the cross section is  $\sigma_0$

$$\sigma_0 = \frac{F}{A} . \quad (1)$$

And on cant  $k - k$  (An angle and vertical direction is  $\alpha$ ) any point of normal stress  $\sigma_\alpha$  and shear stress  $\tau_\alpha$  for

$$\sigma_\alpha = P_\alpha \cos \alpha = \sigma_0 \cos^2 \alpha , \quad (2)$$

$$\tau_\alpha = P_\alpha \sin \alpha = \sigma_0 \cos \alpha \sin \alpha = \frac{\sigma_0}{2} \sin 2\alpha . \quad (3)$$

Note: type (2) and type (3) keep balance with the left section of the stem of normal stress and shear stress; it is not the balance of a particle in section  $k - k$  stress.

by the stress of equal and opposite in balance. A point not be caused artificially in a  $k - k$  inclined section and not in a state of balance (this section is  $k - k$  line point). Cant point to balance on  $k - k$  must by forcing analysis method, namely

$$\sigma'_\alpha = \sigma_0 \cos \alpha , \quad (2\phi)$$

$$\tau'_\alpha = \sigma_0 \sin \alpha . \quad (3\phi)$$

Type (2 $\phi$ ) type (3 $\phi$ ) are to ensure tensile body at any cross section on particle balance stress, because

$$\sigma_{0\text{right}} = \sqrt{(\sigma'_\alpha)^2 + (\tau'_\alpha)^2} = \sqrt{(\sigma_0 \cos \alpha)^2 + (\sigma_0 \sin \alpha)^2} = \sigma_{0\text{left}} .$$

Show a left and right by the size of particles is equal and opposite stress and in balance.

Contrast type (2) type (2 $\phi$ ) is:  $\sigma_\alpha > \sigma'_\alpha$ ; Contrast (3 $\phi$ ) type (3) is:  $\tau_\alpha > \tau'_\alpha$ . This shows that the unit cell balance stress is less than the balance of particles on the stress.

## 2. UNIT BODY UNDER THE STATE OF PLANE STRESS EQUILIBRIUM AND BALANCE OF PARTICLES

### 2.1 In Both Directions Stretch the Particle Balance Stress and Shear Stress Condition

In both directions the tensile and shear stress state, the balance inclined section is deduced by the unit cell as

a normal stress formula (Zhao et al., 2002; Fan & Yin, 2005), for

$$\sigma_\alpha = \frac{\sigma_x + \sigma_y}{2} + \frac{\sigma_x - \sigma_y}{2} \cos 2\alpha - \tau_x \sin 2\alpha . \quad (4)$$

Main stress formula on its main plane (Zhao et al., 2002; Fan & Yin, 2005) for

$$\left. \begin{matrix} \sigma_1 = \sigma_{\max} \\ \sigma_2 = \sigma_{\min} \end{matrix} \right\} = \frac{\sigma_x + \sigma_y}{2} \pm \sqrt{\left(\frac{\sigma_x - \sigma_y}{2}\right)^2 + \tau_x^2} . \quad (5)$$

When  $\sigma_x = \sigma_y = \sigma$ .

Type (5) for

$$\sigma_1 = \sigma_{\max} = \sigma + \tau , \quad (6)$$

$$\sigma_3 = \sigma_{\min} = \sigma - \tau . \quad (6)^*$$

As shown in Figure 2(a) for normal stress and shear stress under the effect of both directions to the tensile and shear stress state.

The stress of the particle a as shown in Figure 2(b), by the resultant force for projection

$$\begin{aligned} \sum x &= \sigma_x + \tau \\ \sum y &= \sigma_y + \tau \end{aligned}$$

The particle stress balance for

$$\sigma'_a = \sqrt{(\sum x)^2 + (\sum y)^2} = \sqrt{(\sigma_x + \tau)^2 + (\sigma_y + \tau)^2} . \quad (7)^*$$

Type (8) is both directions to the stress state of particle balance stress.

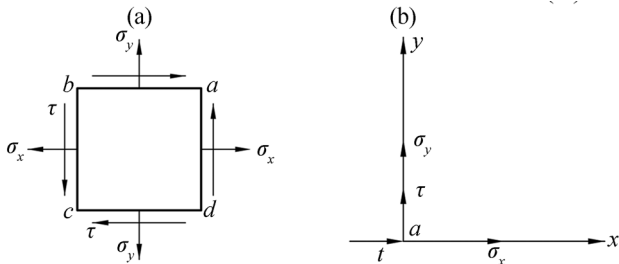

**Figure 2**  
**The State of Balance About Both Directions to Tensile and Shear Stress of Particle for a. (a) Both Directions to the Stress State, (b) Force Diagram of Particle a**

When  $\sigma_x = \sigma_y = \sigma$ , from type (8) for the both directions of particles under tensile stress and shear stress state, such as balance stress

$$\sigma'_a = \sqrt{2}(\sigma + \tau) . \quad (8)$$

Type (6) and type (9) compared to know: Unit body principal stress is less than the particle balance stress, Under plane stress state, the particle balance stress is the main unit body stress maxima of the  $\sqrt{2}$  Times. This shows that the main stress is not extreme stress, particle balance stress is extreme stress.

## 2.2 New Tensile Stress Are Exported Through the Particle Balance - Combinations of Shear Deformation Formula

When  $\sigma_y = 0$  By type (10)\*, Particle stress balance for

$$\sigma'_a = \sqrt{(\sigma_x + \tau)^2 + \tau^2} = \sqrt{\sigma_x^2 + 2\sigma_x\tau + 2\tau^2} , \quad (10)^*$$

type (10) \* is a combination of tensile and shear deformation of particle balance under stress.

Condition is established using particle balance stress intensity (Han & Huang, 2013).

$$\sqrt{\sigma^2 + 2\sigma\tau + 2\tau^2} \leq [\sigma] . \quad (11)^*$$

In type:  $[\sigma]$  is allowable tensile stress.

New strength formula (11)\* is different from the third and fourth strength theory derived from the cell body balance formula (Fan, 2005; Shan, 2007).

$$\sqrt{\sigma^2 + 4\tau^2} \leq [\sigma] , \quad (12)$$

$$\sqrt{\sigma^2 + 3\tau^2} \leq [\sigma] . \quad (13)$$

In type  $[s]$  is material allowable tensile stress.

New stretch - Cut combined deformation formula conform to the yield phenomenon of combination formula (Han & Huang, 2013).

When there is no tensile stress,  $\sigma_y = 0$ , Is the pure shear stress state, The type (11)\*, (12), (13) is simplified to respectively

$$\sqrt{2}\tau \leq [\sigma] ,$$

$$2\tau \leq [\sigma] ,$$

$$\sqrt{3}\tau \leq [\sigma] .$$

When the safety coefficient 1,  $[s]$  is the yield limit  $\sigma_s$ , Can be calculated to yield the relationship between shear stress  $\tau_s$  and the yield limit  $\sigma_s$

$$\tau'_s = \frac{\sqrt{2}}{2} \sigma_s = \sin 45^\circ \sigma_s , \quad (14)$$

$$\tau_{s3} = \frac{1}{2} \sigma_s = \sin 30^\circ \sigma_s , \quad (15)$$

$$\tau_{s4} = \frac{\sqrt{3}}{3} \sigma_s = \sin 35^\circ \sigma_s . \quad (16)$$

In type (14), (15), (16)  $\sigma'_s, \sigma_{s3}, \sigma_{s4}$  respectively particle balance stress, under the third and fourth strength theory, yield shear stress.

The above three types explained the relationship between the yield tensile stress and yields shear stress. The result of type (14) has the same experimental conclusion compared with the low carbon steel tensile, mild steel. Tensile experiment showed that tensile in  $45^\circ$  yield slip line (Zhang & Wang, 2008; Mott, 2005). The type (15) type (16) shows that low carbon steel tensile should be seen in  $35^\circ$  and  $30^\circ$  slip, but is in fact not the case. It proves the correctness of the formula (11)\* that the combination of the strength was reduced through the particle balance.

Compression of brittle materials such as cast iron, its fractured surface, with the axis of around  $45^\circ$  Angle is the maximum shear stress damage, and a new formula to calculate the maximum shear stress occurred in  $45^\circ$  are the same. While the third and the fourth strength theory to calculate the maximum shear stress respectively occurred in  $30^\circ, 35^\circ$ , but the result is not the case.

### 2.3 The New Formula Satisfactory Explanation Tensile-Shear Test Is Easy to Destroy the Phenomenon of Shear-Compression Ratio

Experimental results show that the tensile - shear is easier than compression - shear. This phenomenon can be satisfactorily explained with particle equilibrium stress formula (12)\* : Because the formula (12), and Tensile stress has a non-square items  $2\tau\sigma$  (Zhao, Zhang, & Wang, 2002), When  $\sigma$  is negative values,  $\sigma_a'$  Less than a, which stress makes it difficult to cut the time for positives  $\sigma_a'$ . However, either tension or compression for positive stress  $\sigma$  in the formula (14) and (15),  $\sigma^2$  is positive, its stress is quite equal and you cannot explain this phenomenon. Mohr's strength theory cannot reasonably

explain, with only tensile strength of the material, ranging from pressures to explain this phenomenon, an equal tensile and compressive strength of the material.

### 2.4 New Tension-Shear Strength Formula Combined Deformation Experiments

In order to verify that the new tension-shear deformation correctness intensity formula combination, with the ultimate strength of the plastic PVC, Tsinghua University, State Key Laboratory of damage mechanics, did a stretch-combined strength of shear fracture tests (Han & Huang, 2013), put comparison of experimental data and error for the three theories of fracture stress, reproduced below:

**Table 1**  
**Comparison of Stress Fracture Table Under the Third, Fourth Intensity Particle Equilibrium Conditions and Conditions of Stress Intensity (Han & Huang, 2013)**

No.	Project Tensile stress $\sigma_x$ (MPa)	Shearing stress $\tau_y$ (MPa)	The third strength theory $\sigma_{r3} = \sqrt{\sigma^2 + 4\tau^2}$ (MPa)	The fourth strength theory $\sigma_{r4} = \sqrt{\sigma^2 + 3\tau^2}$ (MPa)	Particle equilibrium stressStrength theory $\sigma_{\sigma\tau} = \sqrt{\sigma^2 + 2\sigma\tau + 2\tau^2}$ (MPa)	Ultimate Tensile Strength $\sigma_b$ (MPa)
1	26.6	7.5	30.6	29.6	40.2	43
2	28.6	12	37	35	42.1	43
3	32.4	9.4	37.5	36.3	42.6	43
4	30.1	15	42.5	39.8	45.1	43
The average			36.9	35.2	42.5	43
Fracture stress and intensity Limit percentage error	$i = \frac{\sigma_b - \sigma_r}{\sigma_b} \times 100\%$		14.2%	18.2%	1%	

Seen from the table: The fracture strength of the material conditions of stress and particle balance resulting tensile stress strength limit error of only 1%. It proved the correctness and accuracy of the new formula. The theory of the third and fourth strength error up to 14.2% and 18.2%. It described that major projects designed by the classical theory of elasticity, especially for bridge, is less safe and it is the main reason for collapse and fracture accident.

Note that the maximum shears stress on the neutral axis ( $y = 0$ ).

Shear beam theory under the new formula (Han & Huang, 2013):

$$\tau' = -\frac{F_s}{|S_z|} y. \quad (18)$$

In type:  $|S_z|$  of the static moment (moment of area) Absolute value . Y of the cross section points to the neutral axis distance. The maximum shears stress by the formula (19) to give a rectangular beam (Han & Huang, 2013)

$$\tau'_{\max} = \frac{2F_s}{bh} = 2\bar{\tau}. \quad (19)$$

In conclusion: (a) Rectangular beam maximum shear stress, the new theory is increased by 33% than the classical theory. (b) The maximum shear stress at the neutral axis of the classical theory, the new theory of shear stress in the beam at the upper and lower surfaces. The upper and lower surfaces of the beam are stretched - plane shear stress, but the classical elasticity theory only by uniaxial stress state.

### 3. SHEAR STRESS DISTRIBUTION OF THE NEW THEORY AND THE CLASSICAL THEORY OF THE BEAM CROSS-SECTION

Current elasticity theory is deduced on the transverse cross-section rectangular beam maximum shear stress (Mott, 200; Qian & Ye, 1956; Huang, 1982)

$$\tau_{\max} = \frac{3}{2} \frac{F_s}{A} = 1.5\bar{\tau}. \quad (17)$$

In type: On cross-section of the shear. A of the cross-sectional area.  $\bar{\tau}$  of the average shear stress.

## 4. NEW TENSION - SHEAR DEFORMATION COMBINATION FORMULA FOR BRIDGE DESIGN

As shown in Figure 3(a) shown in multi-span statically

indeterminate beams, AC and CB are connected by beams formed by the hinge C. The cross section of C is box-shaped beam. Figure 4 Materials for the low-alloy steel, Allowable tensile stress  $[\sigma] = 210\text{Mpa}$   $[\tau] = 100\text{Mpa}$ ; Try checking the strength of the two theories beam.

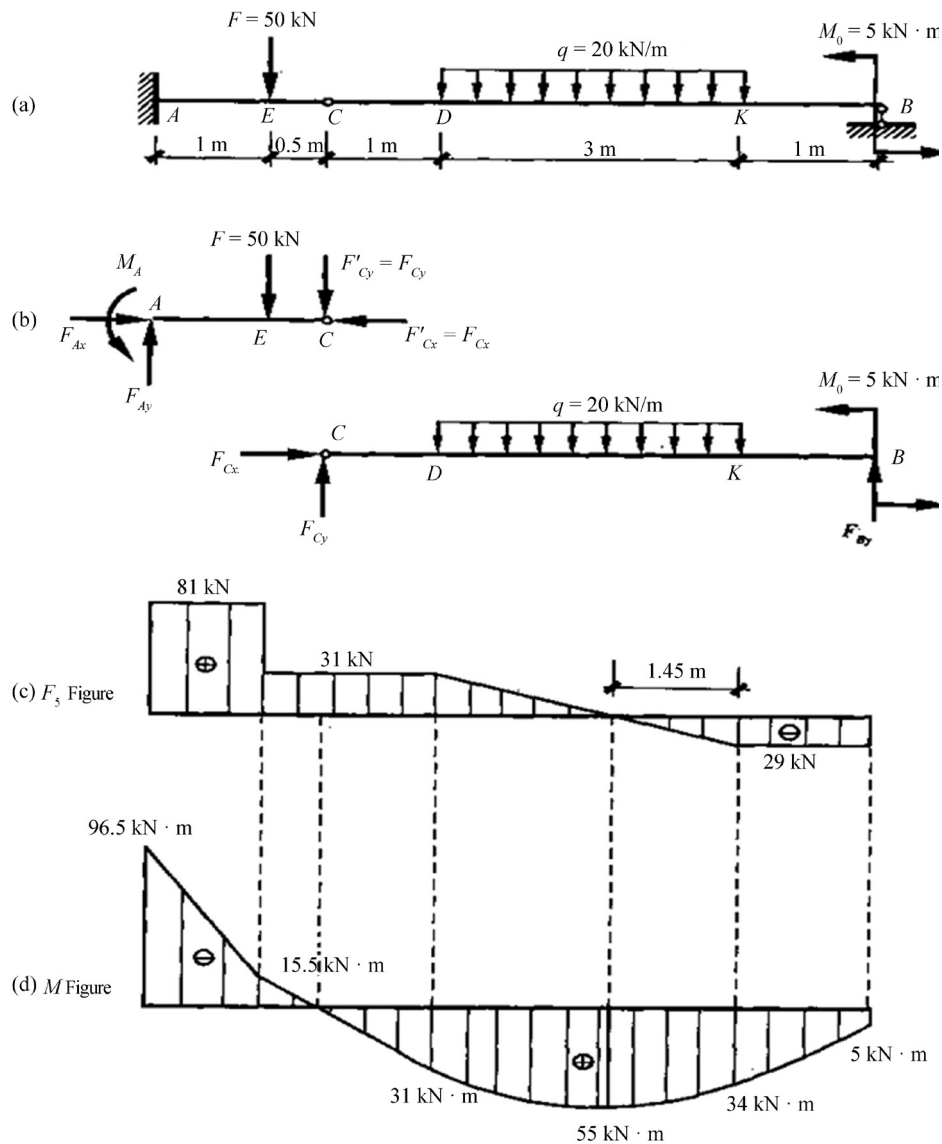

**Figure 3**  
**Beam Shear and Bending Moment Diagram**

a) Structure and distribution of the load beam shown in Figure 3(a).

b) Shear and bending moment diagram as Figure 3(c)

and (d), (calculation omitted).

c) The basic dimensions of the box beam in Figure 4.



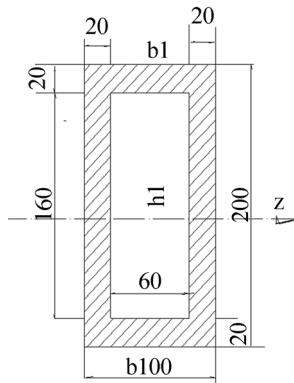

**Figure 4**  
The Basic Size Box Girder

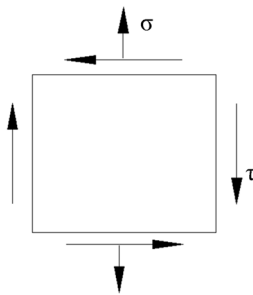

**Figure 5**  
A Stress Beam End Point  $y = h/2$

d) Rectangular beam absolute quiet moments (Note: The centroid of absolute quiet moment is not zero)

$$|S_z| = \frac{bh^2}{4} = \frac{1}{4}(0.1 \times 0.2^2 - 0.06 \times 0.16^2) = 6.16 \times 10^{-4} \text{ m}^3$$

e) The moment of inertia for Z of the neutral axis

$$\begin{aligned} \sigma'_A &= \sqrt{\sigma^2 + 2\sigma\tau + 2\tau^2} = \sqrt{(209 \times 10^6)^2 + 2 \times 209 \times 10^6 \times 13.15 \times 10^6 + 2(13.15 \times 10^6)^2} \\ &= 222.5 \text{ Mpa} . \end{aligned}$$

Since  $\sigma'_A = 222.5 \text{ Mpa} > [\sigma] = 210 \text{ Mpa}$  .

The visible beam for the end of A's strength is not enough.

The  $\sigma'_A$  percentage is greater than  $[\sigma]$  for

$$i_\sigma = \left| \frac{210 - 222.5}{210} \right| \times 100\% = 6\% > 5\% .$$

We must change the structure and re-press particle equilibrium conditions of stress intensity design for bridge is unsafe.

## REFERENCES

- Liu, H. W. (2000). *Mechanics of materials*. Beijing: Higher Education Press.
- Han, W. B., & Huang, S. H. (2013). *Nonzero moment on a unit area elasticity theory*. Chongqing: Chongqing University Press.

$$I_z = \frac{bh^3}{12} - \frac{b_1h_1^3}{12} = \frac{1}{12}(0.1 \times 0.2^3 - 0.06 \times 0.16^3) = 4.618 \times 10^{-5} \text{ m}^4$$

f) A positive side by the beam negative moment of maximum stress generated

$$\sigma_{A\max} = \frac{M_{\max}}{I_z} y_{\max} = \frac{96.5 \times 10^3 \cdot 0.2}{4.618 \cdot 2} = 209 \text{ Mpa} .$$

Since  $\sigma_{A\max} = 209 \text{ Mpa} < [\sigma] = 210 \text{ Mpa}$  .

The beam is safe when it's under positive stress .

g) A side beam shear stress maximum shear generated (Han & Huang, 2013)

$$\tau_{A\max} = \frac{F_{s\max}}{|S_z|} y_{\max} = \frac{81 \times 10^3 \cdot 0.2}{6.16 \times 10^{-4} \cdot 2} = 13.15 \text{ Mpa} .$$

Since  $\tau_{A\max} = 13.15 \text{ Mpa} < [\tau] = 100 \text{ Mpa}$ .

The shear stress at the beam is safe.

H) A combination of stress (James, 2002; Luo, 2004; Huang, 1982) strength check under

At the upper surface of  $y = h/2$  the upper beam end point, A stress state is shown in 4.3.

① Check the third strength theory

$$\sigma_{Ar3} = \sqrt{\sigma^2 + 4\tau^2} = \sqrt{209^2 + 4 \times 13.15^2} = 210.6 \text{ Mpa} .$$

The third strength theory can be seen to meet the strength requirements.

② Checking fourth strength theory

$$\sigma_{Ar4} = \sqrt{\sigma^2 + 3\tau^2} = \sqrt{209^2 + 3 \times 13.15^2} = 210.2 \text{ Mpa} .$$

The fourth strength theory can meet the strength requirements

③ The check of the stress conditions combined strength for particle equilibrium (Han & Huang, 2013).

- Fan, Q. S., & Yin, Y. J. (2005). *Mechanics of materials*. Beijing: Tsinghua University Press.
- Zhao, J. J., Zhang, S. S., & Wang, C. X. (2002). *Mechanics of materials*. China: Harbin Institute of Technology Press.
- James, M. G. (2002). *Mechanics of materials*. Beijing: Mechanical Industry Press.
- Mott, P. (2005). *Applied strength of materials*. Chongqing, China: Chongqing University Press.
- Qian, W. C., & Ye, K. Y. (1956). *Elasticity*. Beijing: Science Press.
- Luo, Y. S. (2004). *Mechanics of Materials*. Wuhan, China: Wuhan University Press.
- Shan, Z. H., & Xie, C. F. (2007). *Engineering mechanics*. Beijing: Beijing Higher Education Press.
- Huang, Y. (1982). *Engineering elasticity*. Beijing: Tsinghua University Press.
- Zhang, R. S., & Wang, T. M. (2008). *Mechanics of materials*. Beijing: China Building Industry Press.